

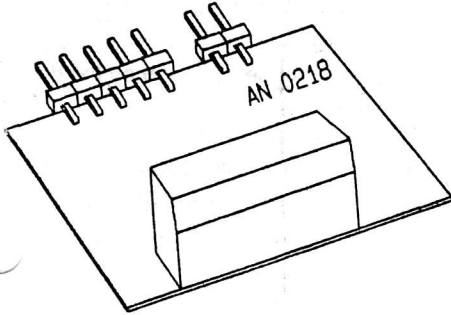

**BITRON VIDEO s.r.l.**

Via Torino 21/b - 10044 PIANEZZA (TO) Italy  
Tel. +39 11 968.46.11 (r.a.) - Fax +39 11 966.31.49



**SCHEMA 1 + 1  
1 + 1 CARD  
CARTE 1 + 1**

**A N 0 2 1 8**



Il dispositivo AN 0218 è costituito da un circuito elettronico predisposto per essere inserito all'interno del citofono intelligente AN 1000 e AN 1018.

L'impiego di tale schedino consente di trasformare il citofono rendendolo adatto a funzionare in impianti con fonica 1 + 1 (P.E. AK 5269 oppure GCM 70/20 e /21).

Il citofono così trasformato potrà essere utilizzato anche negli impianti video con gruppi G 60, G 60K, GVM 70 e negli impianti con centralino di portineria.

AN 0218 device is made of an electronic circuit pre-arranged for the insertion inside the intelligent door phones AN 1000 and AN 1018.

The use of this card allows transforming the door phone making it suitable to operate in systems with 1 + 1 speech (loudspeaking unit AK 5269 or GCM 70/20 and /21).

The door phone so transformed can be used in conjunction with systems with G 60, G 60K, GVM 70 camera units and with systems with doorkeeper switchboard.

Le dispositif AN 0218 se compose d'un circuit électronique prédisposé pour l'insertion dans le combiné intelligent AN 1000 et AN 1018.

L'utilisation de cette carte permet de transformer le combiné pour le fonctionnement avec phonie p 1 + 1 fils (micro-HP AK 5269 ou GCM 70/20 et /21).

Le combiné ainsi transformé pourra-t-être utilisé aussi dans les systèmes vidéo avec unités de prise de vue G 60, G 60K, GVM 70 et dans les systèmes vidéo avec central de conciergerie.

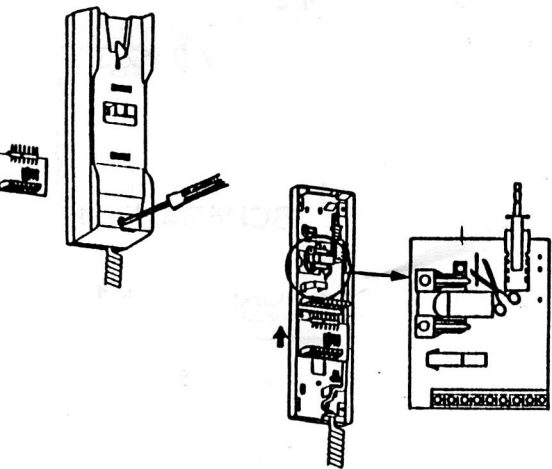

Aprire il citofono e inserire lo schedino AN 0218 nella morsetteria come indicato in figura.

— tagliare il ponticello \* presente sul circuito stampato del citofono stesso.  
Open the door phone and insert the card AN 0218 in the terminal board as indicated.

— remove bridge \* present on the door phone terminal board.

Ouvrir le combiné et insérer la carte AN 0218 dans le bornier comme indiqué.

— couper le pontet \* présent sur le circuit imprimé du combiné même.

Serrare le viti della morsetteria del citofono verificando con cura che tutte le spinette dello schedino aggiuntivo siano ben serrate nel morsetto.

Tighten the door phone terminal board screws checking that all the card pins are well tightened on the terminal.

Serrer les vis du bornier du combiné vérifiant que toutes les petites fiches de la carte soient bien serrées dans la borne.

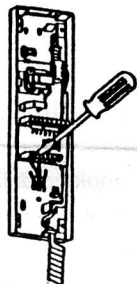

Collegare la morsetteria dello schedino aggiuntivo ai fili dell'impianto come da schemi allegati.

Connect the card terminal board to the system's wires as indicated in the enclosed schemes.

Brancher le bornier de la carte aux fils du système comme indiqué dans les schémas annexés.

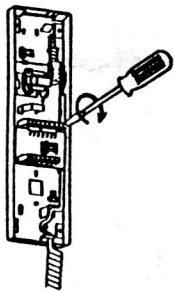

Richiudere il citofono  
Close the door phone  
Fermer le combiné

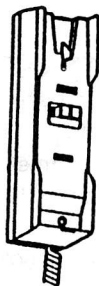

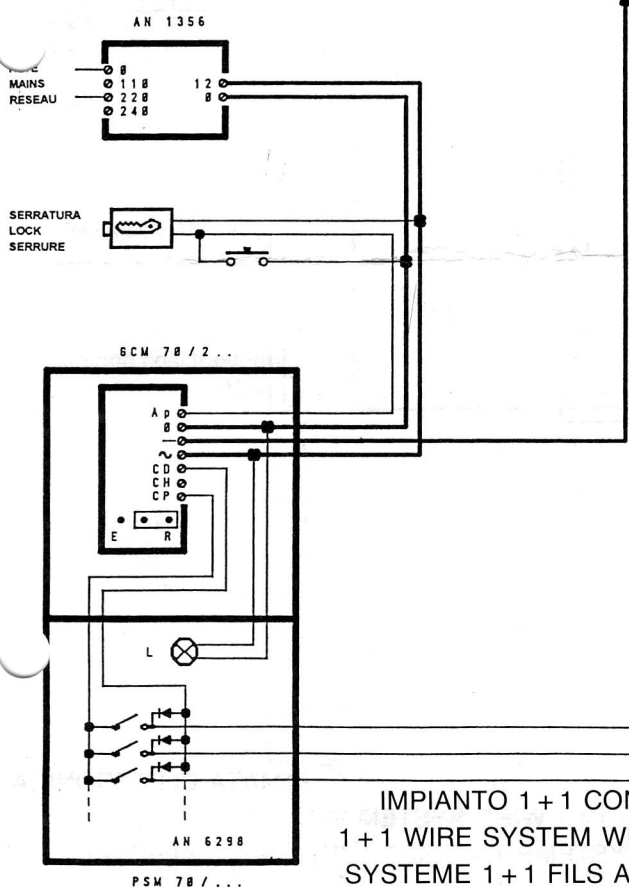
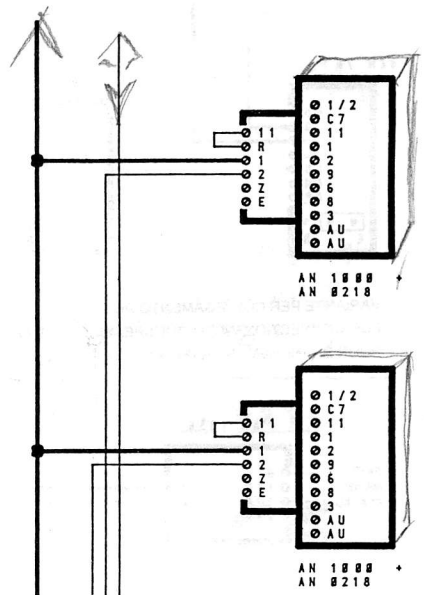
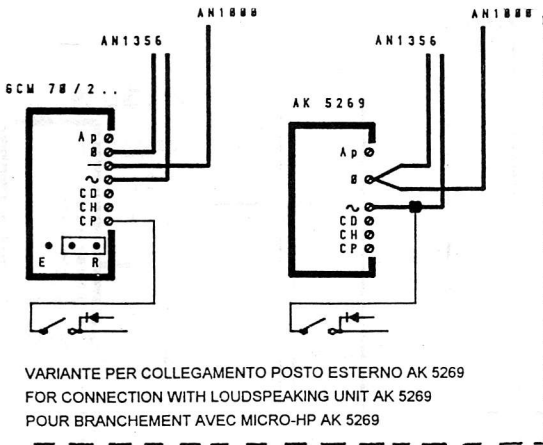

EFFEU V  
 RAPP. 1  
 070 872169

IMPIANTO 1 + 1 CON CHIAMATA RONZATORE  
 1 + 1 WIRE SYSTEM WITH CALL THROUGH BUZZER  
 SYSTEME 1 + 1 FILS AVEC APPEL PAR RONFLEUR

I collegamenti devono essere eseguiti rigorosamente come indicato nello schema al fine di evitare ronzii.  
 Connections have to be made as indicated in the scheme in order to avoid buzzing.  
 Les connexions devront être exactement comme indiqué sur le schéma pour éviter les problèmes de ronflement.

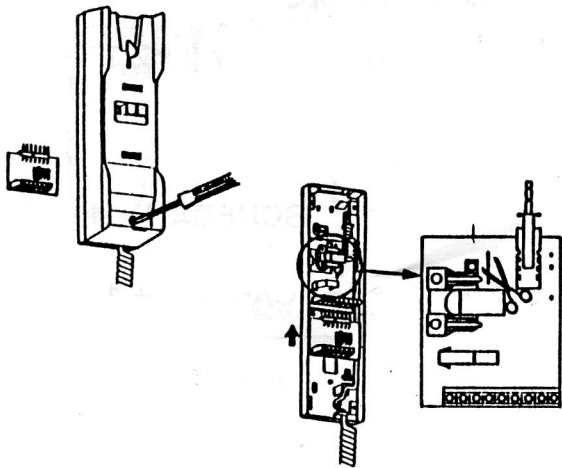

Aprire il citofono e inserire lo schedino AN 0218 nella morsetteria come indicato in figura.

— tagliare il ponticello \* presente sul circuito stampato del citofono stesso.  
 Open the door phone and insert the card AN 0218 in the terminal board as indicated.

— remove bridge \* present on the door phone terminal board.

Ouvrir le combiné et insérer la carte AN 0218 dans le bornier comme indiqué.

— couper le pontet \* présent sur le circuit imprimé du combiné même.

Serrare le viti della morsetteria del citofono verificando con cura che tutte le spinette dello schedino aggiuntivo siano ben serrate nel morsetto.

Tighten the door phone terminal board screws checking that all the card pins are well tightened on the terminal.

Serrer les vis du bornier du combiné vérifiant que toutes les petites fiches de la carte soient bien serrées dans la borne.

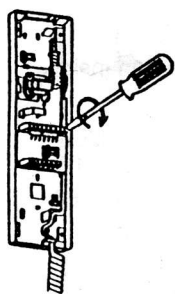
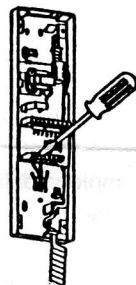

Collegare la morsetteria dello schedino aggiuntivo ai fili dell'impianto come da schemi allegati.

Connect the card terminal board to the system's wires as indicated in the enclosed schemes.

Brancher le bornier de la carte aux fils du système comme indiqué dans les schémas annexés.

Richiudere il citofono  
 Close the door phone  
 Fermer le combiné

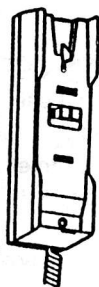

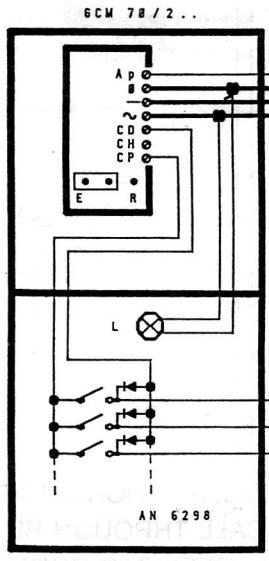
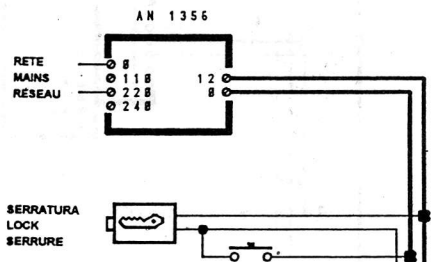
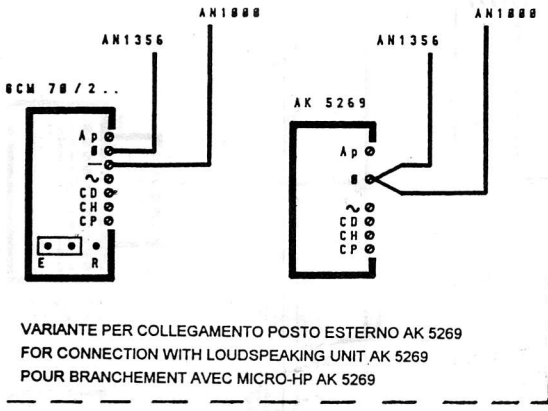

**IMPIANTO 1 + 1 CON CHIAMATA ELETTRONICA**  
**1 + 1 WIRE SYSTEM WITH ELECTRONIC CALL**  
**SYSTEME 1 + 1 FILS AVEC APPEL ELECTRONIQUE**

I collegamenti devono essere eseguiti rigorosamente come indicato nello schema al fine di evitare ronzii.

Connections have to be made as indicated in the scheme in order to avoid buzzing.  
 Les connexions devront être faites exactement comme indiqué sur le schéma pour éviter les problèmes de ronflement.

