

**VIDEOSET CON PULSANTIERA SINTHESI E VIDEOCITOFONO**

***VIDEOSET WITH SINTHESI PUSH BUTTON PANEL AND  
VIDEO DOOR PHONE***

**Sch./Ref. 1702/611-/612**

**Sch./Ref. 1704/611-/612**

**Sch./Ref. 1704/621-/622**

**Sch./Ref. 1702/601-/602**

**Sch./Ref. 1704/601-/602**

## NOTE LEGATE AGLI SCHEMI DIAGRAM NOTES

### V5.001: SEZIONI DEI CONDUTTORI

Distanza max.		m	50	100	200
Conduttori	R1	S mmq	0,75	1,5	2,5
	R2	S mmq	0,5	1,0	2,0
	CA	S mmq	0,35	0,50	0,75
	A, B	S mmq	0,35	0,35	0,35 binati

Le distanze s'intendono tra l'unità di ripresa ed il videocitofono più lontano. Fino a 100 m si possono utilizzare conduttori normali; per distanze superiori, fino a 200m, i conduttori A e B devono essere binati tra di loro.

#### WIRE CROSS-SECTION AREAS

Max. distance		m	50	100	200
Wires	R1	Sq mm	0.75	1.5	2.5
	R2	Sq mm	0.5	1.0	2.0
	CA	Sq mm	0.35	0.50	0.75
	A, B	Sq mm	0.35	0.35	0,35 double wires

*The diagrams indicate the distance between the camera and most distant video door phone unit. Normal wires can be used for distances up to 100 metres. For higher distances (up to 200 metres) the wires A and B must be doubled.*

**V5.006:** La distanza massima fra i due dispositivi è 50 metri.

*The maximum distance between devices is 50 metres.*

### VX.003: SEZIONI MINIME DEI CONDUTTORI

Distanza	m	50	100	200	300
Conduttori normali	mmq	0,5	0,8	1	1,6
Conduttori R1, R2, +TC	mmq	0,8	1	1,6	2,5
CAVO COAX 75 Ohm	Fino a 300 m usare cavo coassiale normale. Oltre tale distanza occorre inserire un amplificatore video.				

#### MINIMUM WIRE CROSS-SECTION AREAS

Distance	m	50	100	200	300
Normal Wires	mmq	0.5	0.8	1	1.6
Wires R1, R2, +TC	mmq	0.8	1	1.6	2.5
COAXIAL CABLE 75 Ohm	Use a normal coaxial wire for distances up to 300 m add a video amplifier for longer distances.				

**VIDEOKIT V1 COAX Sch./Ref. 1702/611**  
**VIDEOKIT V2 COAX Sch./Ref. 1702/612**

**SV102-3146B**  
 (VX.003)

Sch./Ref. 1702/1  
 VIDEOCITOFONI  
 VIDEO DOORPHONES  
 Mod. ATLANTICO  
 +  
 Sch./Ref. 1202/90  
 STAFFA  
 BRACKET

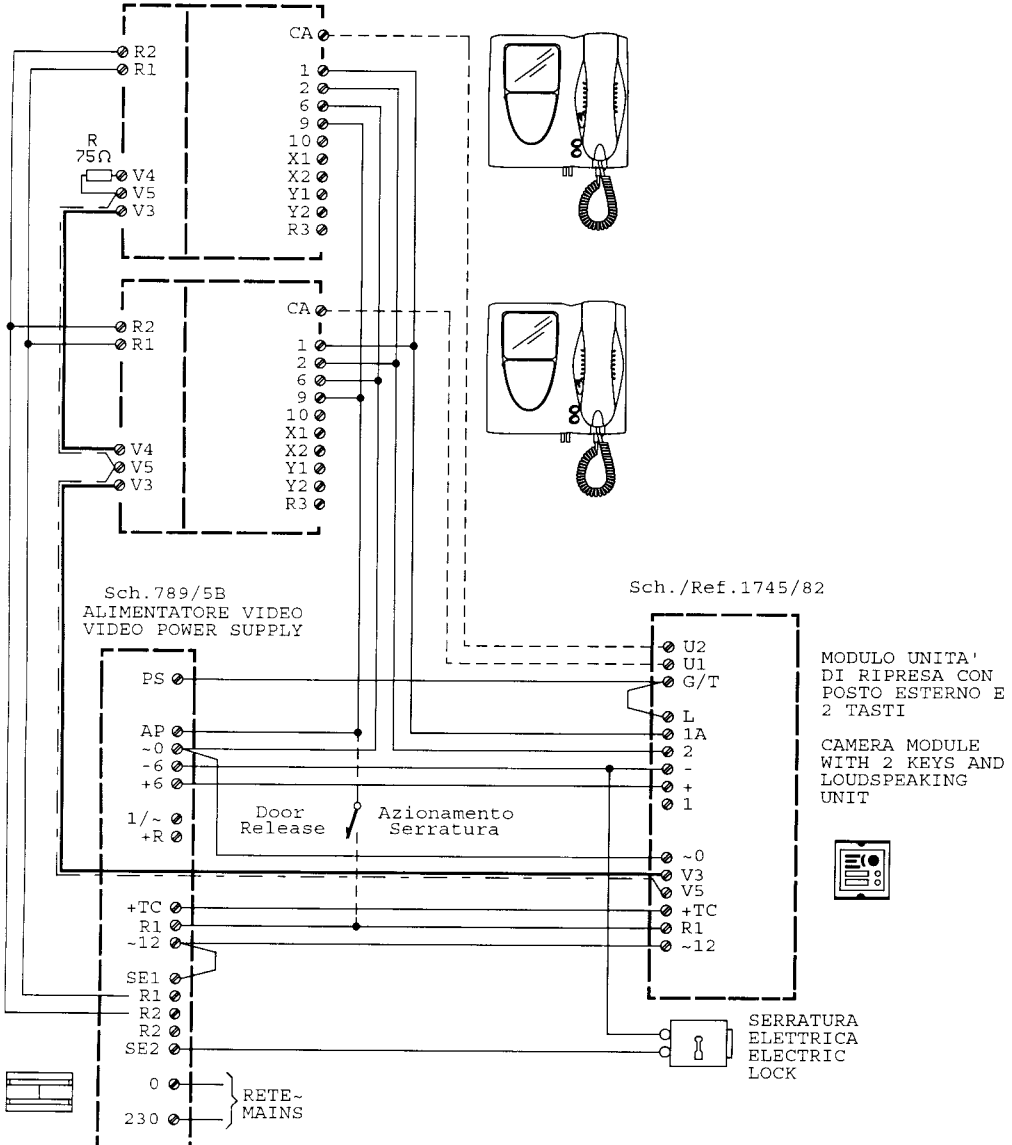

**SENTRYSET V1 COAX Sch./Ref. 1704/611**  
**SENTRYSET V2 COAX Sch./Ref. 1704/612**

**SV102-3148A**  
 (VX.003)

Sch./Ref.1704/1A  
 VIDEOCITOFONI  
 VIDEO DOORPHONES  
 Mod. SENTRY+

+  
 Sch./Ref.1704/90  
 STAFFA  
 BRACKET

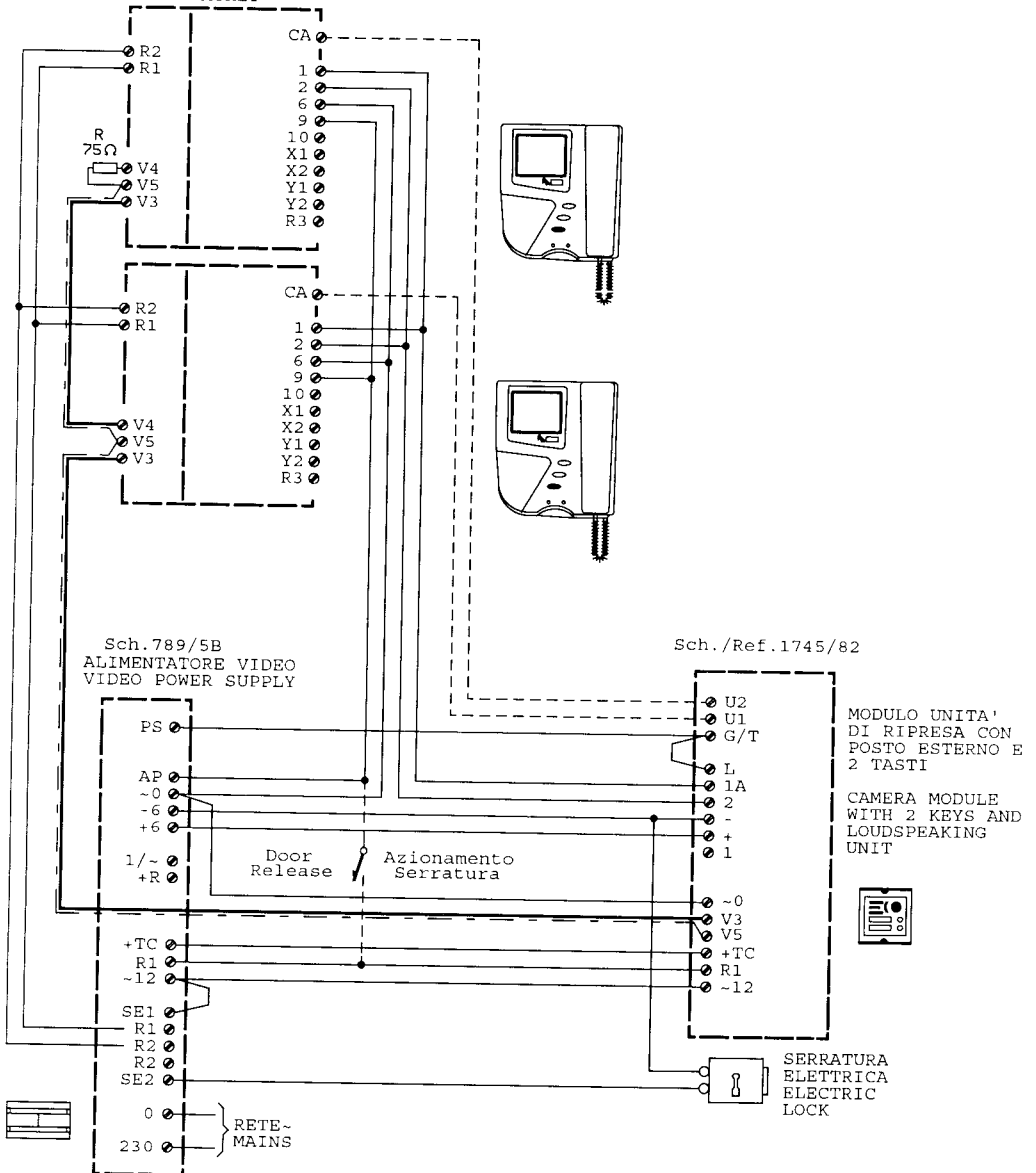

**SENTRYSET V1 COAX REFLEX Sch./Ref. 1704/621**  
**SENTRYSET V2 COAX REFLEX Sch./Ref. 1704/622**

**SV102-3150A**  
 (VX.003)

Sch./Ref.1704/10A  
 VIDEOCITOFONI  
 VIDEO DOORPHONES  
 Mod. SENTRY+  
 +  
 Sch./Ref.1704/90  
 STAFFA  
 BRACKET

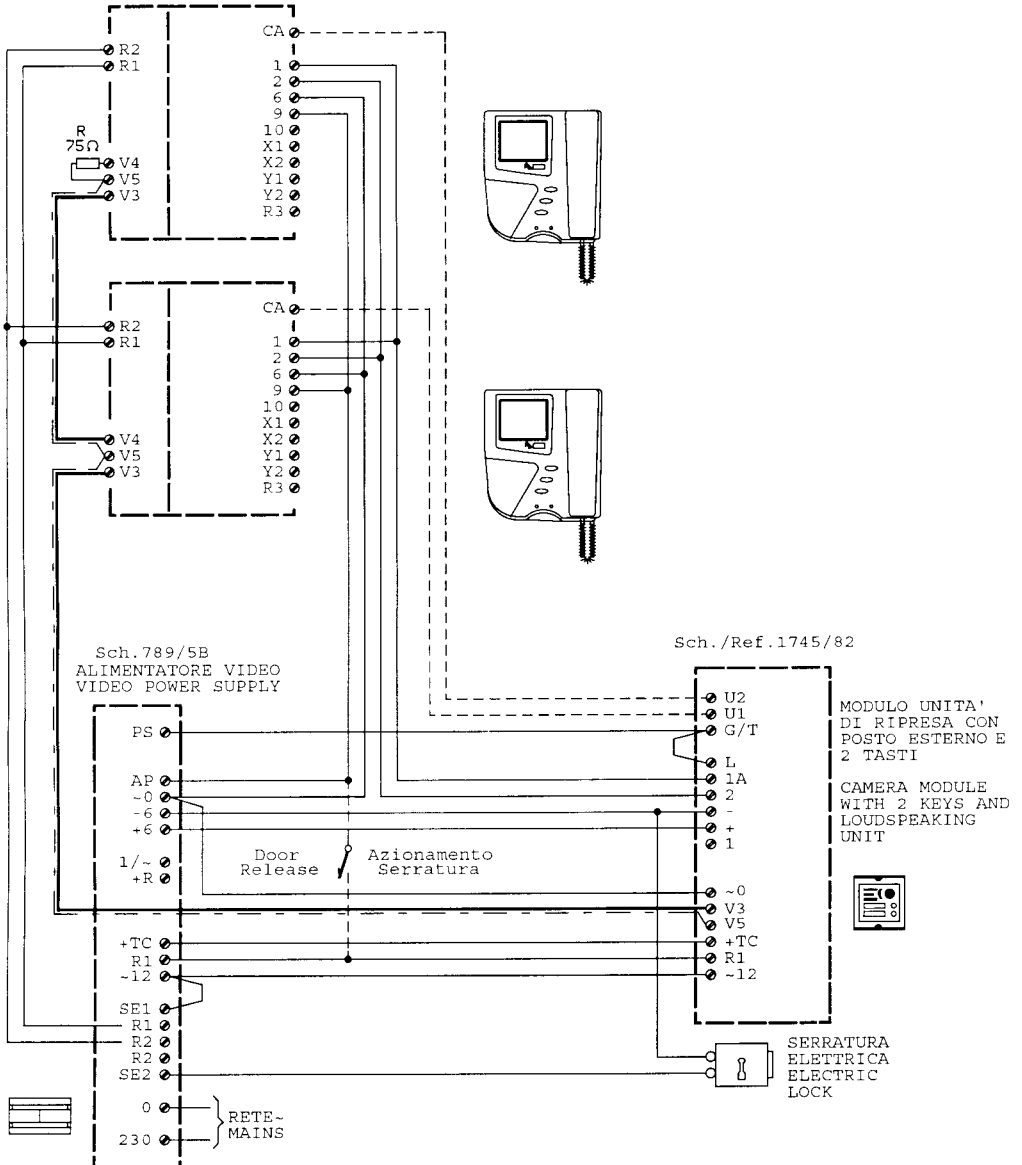

**VIDEOKIT V1 5 FILI Sch. 1702/601**  
**5 WIRE V1 VIDEOKIT Ref. 1702/601**

**VIDEOKIT V2 5 FILI Sch. 1702/602**  
**5 WIRE V2 VIDEOKIT Ref. 1702/602**

**SV102-3147A**  
 (V5.001)

Sch./Ref.1702/1  
 VIDEOCITOFONI  
 VIDEO DOORPHONES  
 Mod. ATLANTICO

+  
 Sch./Ref.1202/955  
 STAFFA  
 BRACKET

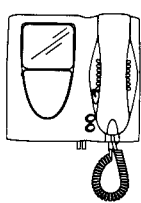

(V5.006)

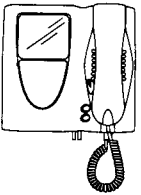

Sch./Ref.1745/22



MODULO UNITA'  
 DI RIPRESA CON  
 POSTO ESTERNO E  
 2 TASTI  
 CAMERA MODULE  
 WITH 2 KEYS AND  
 LOUDSPEAKING UNIT

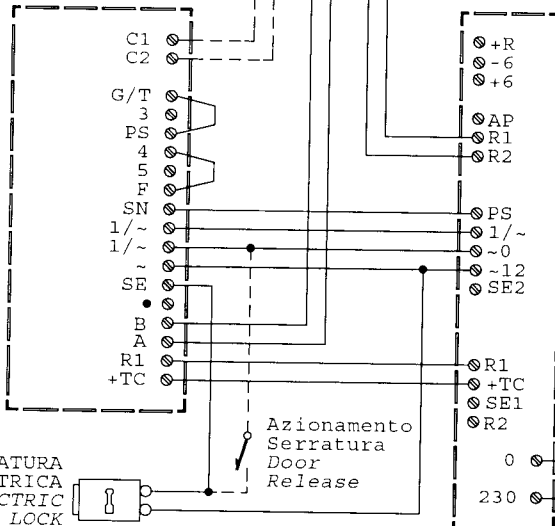

Sch./Ref.789/5B  
 ALIMENTATORE  
 VIDEO  
 VIDEO  
 POWER SUPPLY

SERRATURA  
 ELETTRICA  
 ELECTRIC  
 LOCK

Azionamento  
 Serratura  
 Door  
 Release

0 } RETE~  
 230 } MAINS~

**SENTRYSET V1 5 FILI REFLEX Sch. 1704/601**  
**5 WIRE V1 SENTRYSET REFLEX Ref. 1704/601**

**SENTRYSET V2 REFLEX Sch. 1704/602**  
**5 WIRE V2 SENTRYSET REFLEX Ref. 1704/602**

**SV102-3149**  
 (V5.001)

Sch./Ref.1704/10A  
 VIDEOCITOFONI  
 VIDEO DOORPHONES  
 Mod. SENTRY+

+  
 Sch./Ref.1704/955  
 STAFFA  
 BRACKET

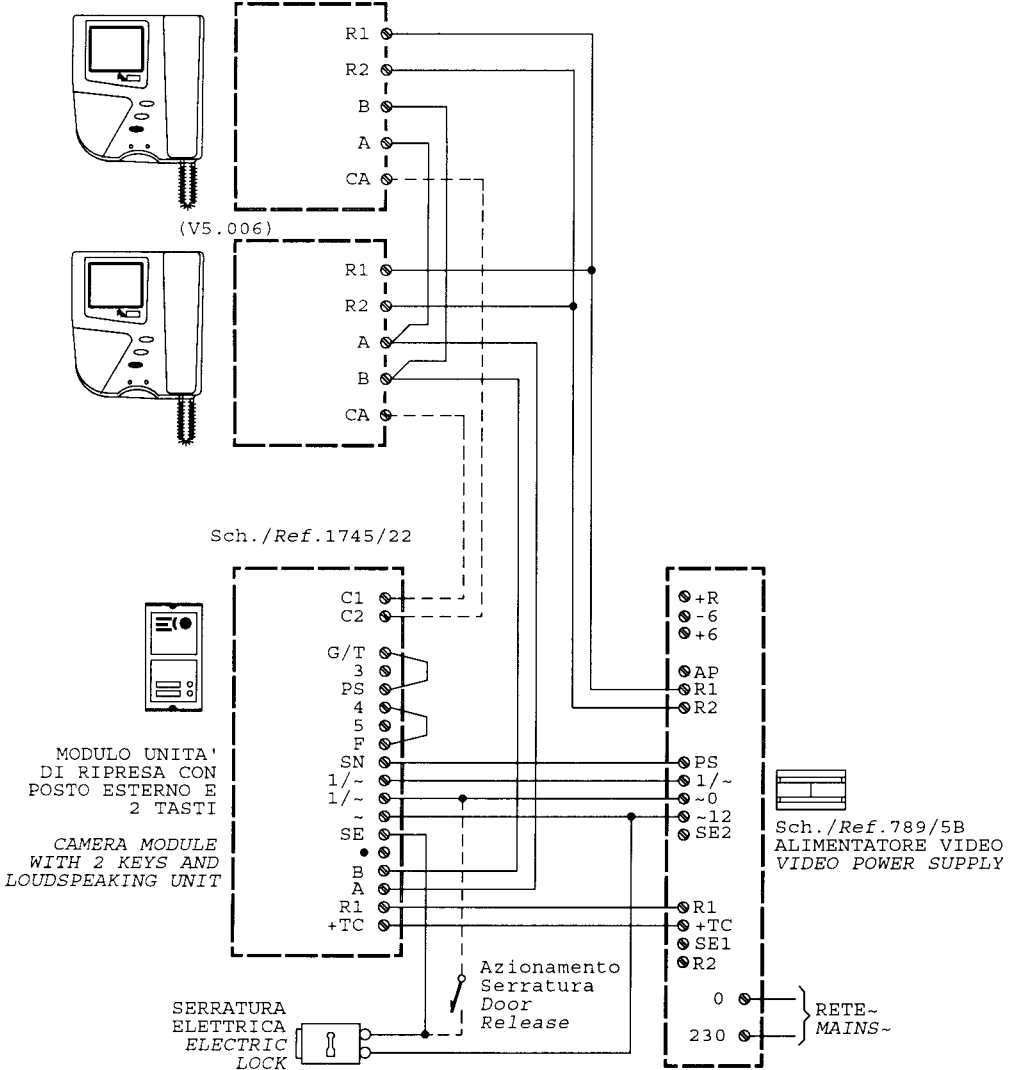

DS 1702-005A

**urmet**  
DOMUS

LBT 7715

**FILIALI**

20151 MILANO - Via Gallarate 218  
Tel. 02.380.111.75 - Fax 02.380.111.80  
00043 CIAMPINO (ROMA) - Via L.Einaudi 17/19A  
Tel. 06.791.07.30 - Fax 06.791.48.97  
80013 CASALNUOVO (NAPOLI)  
Via Nazionale delle Puglie 3  
Tel. 081.193.661.20 - Fax 081.193.661.04  
30030 VIGONOVO (VENEZIA) - Via del Lavoro 71  
Tel. 049.738.63.00 r.a. - Fax 049.738.63.11



<http://www.urmetdomus.com>  
e-mail: [info@urmetdomus.it](mailto:info@urmetdomus.it)

**STABILIMENTO**

URMET DOMUS S.p.A.  
10154 TORINO (ITALY)  
VIA BOLOGNA 188/C  
Telef. 011.24.00.000 (RIC. AUT.)  
Fax 011.24.00.300 - 323  
Call Center 011.23.39.801